

Friction Force Measurement in Reciprocating Tribometers

A G Plint – STLE 2011

Abstract

The transfer function of measuring systems for friction in tribological experiments is rarely analysed. This is of concern in reciprocating experiments, where claimed effects are not actual friction effects, but measurement artefacts or system resonance. For a measuring system with a fixed signal bandwidth, increasing the reciprocating frequency causes the apparent mean force to fall, giving the appearance of a reduction in friction with increasing frequency. As reciprocating frequency increases relative to the frequency response of the measuring system, the information content of the signal decreases. The transition from static to dynamic friction at the beginning of each stroke “plucks” the force measuring system. The magnitude of the resulting oscillations is a function of the magnitude of the plucking force and the rate of decay of the resulting vibration is a function of the resonant frequency of the measuring system and the variable damping coefficient of the frictional contact.

Introduction

Measurement of a dynamic force presents a number of challenges, frequently ignored, when that dynamic force is associated with a tribological experiment. Rarely, if ever, do published papers make any reference to the transfer function of the measuring system used to sense friction. Although this is by no means a new problem, this paper aims to explore key issues associated with nominal friction force measurements in reciprocating tribometers, with particular reference to well established commercially available test machines. The same concerns apply to other dynamic friction devices, such as engines fitted with floating pistons for ring/liner friction force measurement.

The motivation for writing the paper has been receipt of numerous requests to comment on and explain dynamic friction force signals and how these should be filtered and processed. It is clear that many “claimed” friction effects are not actually real friction effects, but are either measurement artefacts or system resonance. Two key issues will be explored in this paper, firstly, the effect of frequency response of a measuring system and, secondly, the effect of the transition from static friction to dynamic friction on measuring system resonance, but our starting point will be a brief review of system response and sampling rates.

Frequency Response of Measuring Systems

The information content available in the signal channels of a dynamic testing machine is directly related to the signal bandwidth. The fundamental limitation in most measuring systems is the bandwidth of the transducer itself.

It is generally accepted that, in order to keep measuring errors low, a measuring system should not be used at frequencies above about 0.3 of its resonant frequency and input filtering is imposed to limit the signal bandwidth accordingly.

It is normal to apply filtering on measuring channels in order to eliminate higher frequency signal noise and aliasing. The same characteristic filter should be used on all channels, especially in high frequency systems, to ensure that the information from different channels can be directly correlated and is not subject to differing time delays, in other words, phase shifts between signals.

When sampling the signals processed by a filter it is important to sample at high enough a rate to preserve the information in the original signal. The Nyquist Sampling Theory indicates that the minimum acceptable sampling rate is twice the maximum detectable frequency. The measured amplitudes of signals at half the Nyquist sampling rate are attenuated to 64% of their true value. The Sampling rate of the system should thus be well matched to its signal bandwidth in order to preserve information content.

Aliasing

Aliasing occurs when the sampling rate is too low for the frequency response of the system. As a simple example of aliasing, consider sampling the levels of illumination by looking out of the window, at the same time, just once per day. If the observations were always made at midnight, the collected data would imply that it was always dark outside. If the observations were always made at midday, the collected data would imply that it was always light outside.

Now, assuming that there are twelve hours of darkness and twelve hours of light, consider taking three samples per day, at eight hours interval. If sampled at 1200, 2000 and 0400, the observations will indicate twice as much dark as light. If sampled at 0000, 0800 and 1600, the observations will indicate twice as much light as dark.

As the signal is varying twice per day (from day to night) the absolute minimum sampling rate in order to avoid aliasing would be four equi-spaced observations per day.

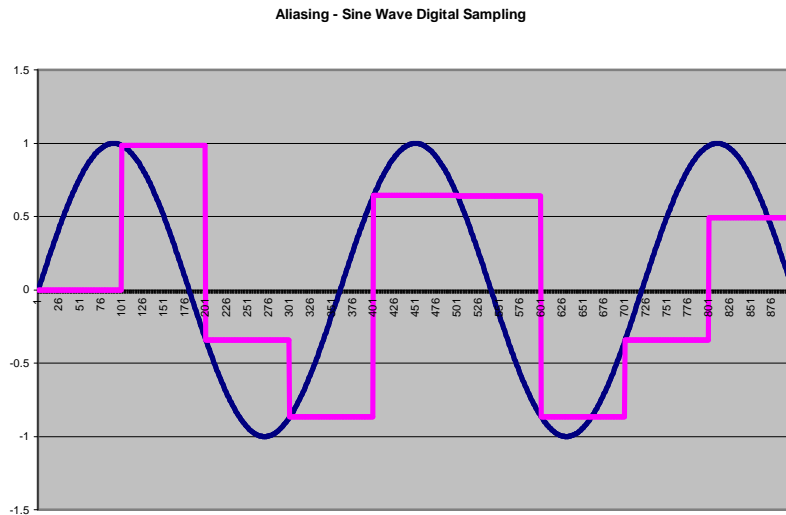

The above graph shows the effect aliasing when sampling a sine wave every 100 degrees, which is equivalent to sampling a 360 Hz signal with a 100 Hz sampling rate.

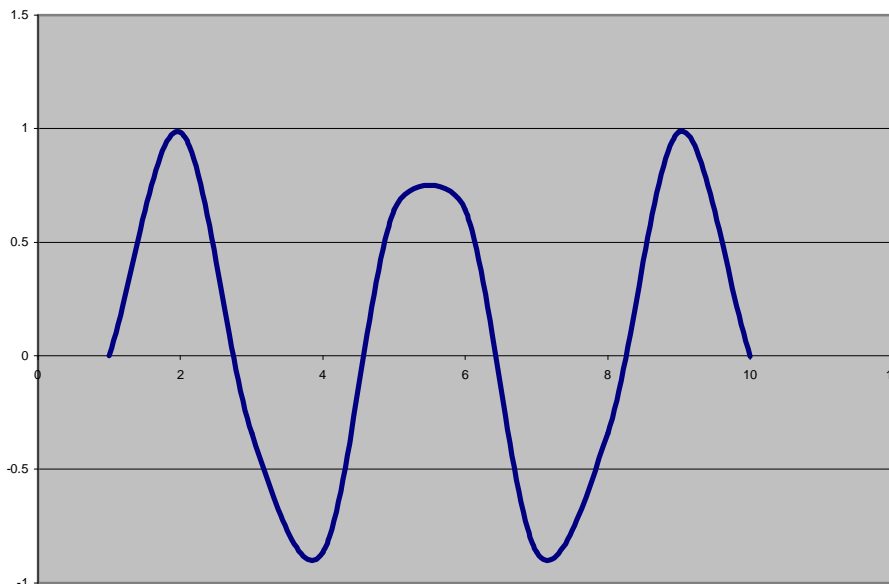

The above graph shows the 100 degree sampled data plotted with a “curve fitting” graph setting.

Phase Angle Errors

Ignoring the effects of frequency response can give rise to some spectacular errors. This is especially the case where one dynamic signal is divided by another, in order to

give, for example, a friction coefficient reading. The following provides a graphical illustration of this point:

Equal Frequency Response & Zero Phase Shift

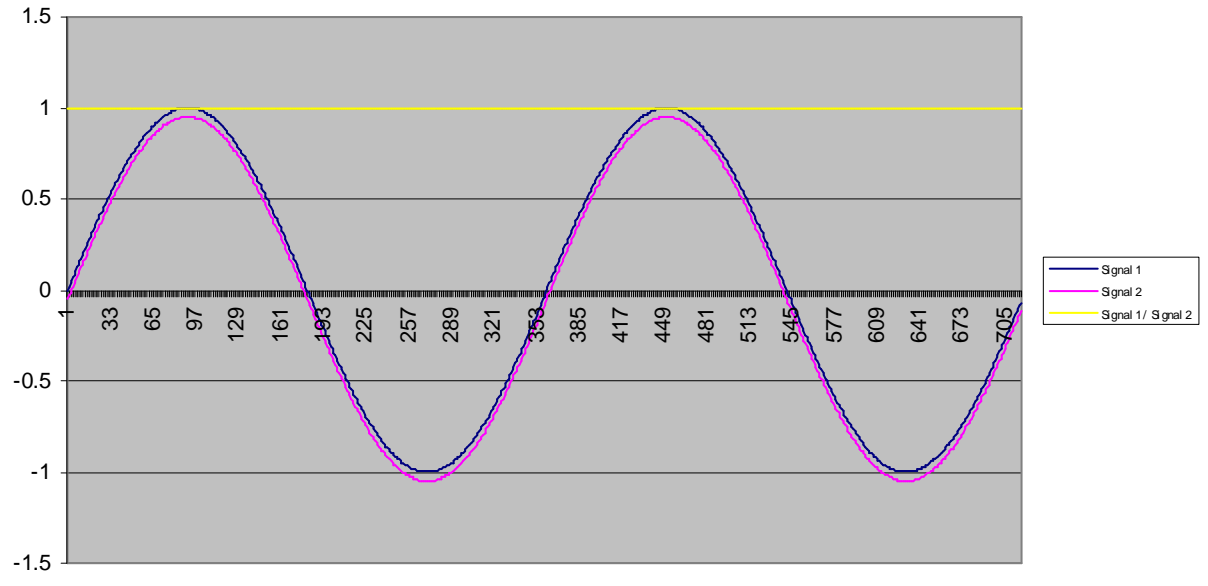

Effect of Phase Shift

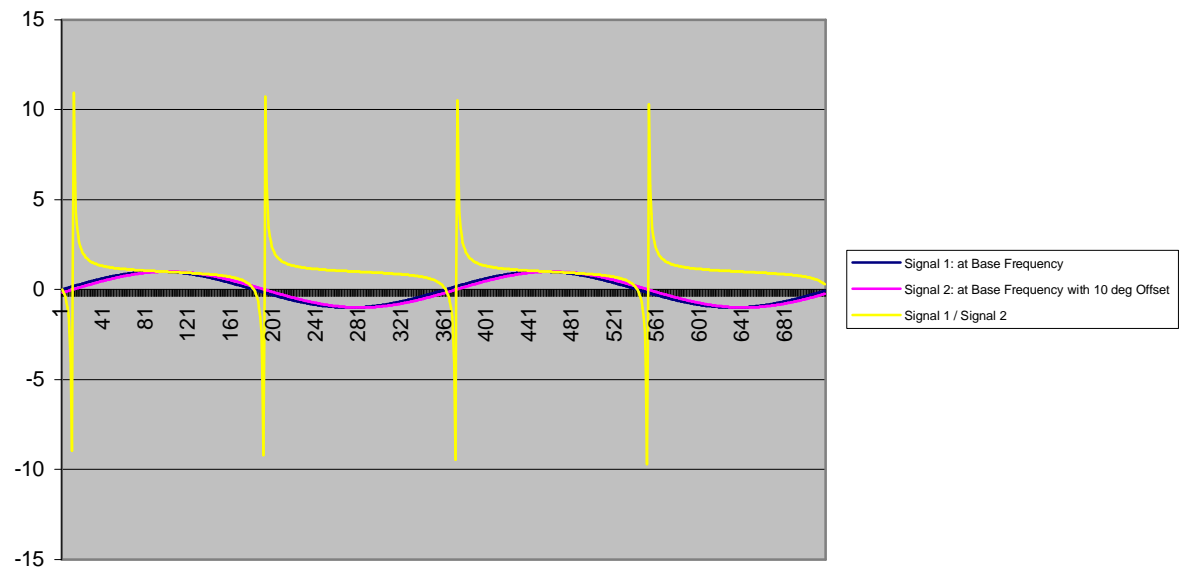

Transducer Natural Frequency

This is a diagram of a typical transducer and stationary specimen carrier (as used on the TE 77 High Frequency Friction Machine):

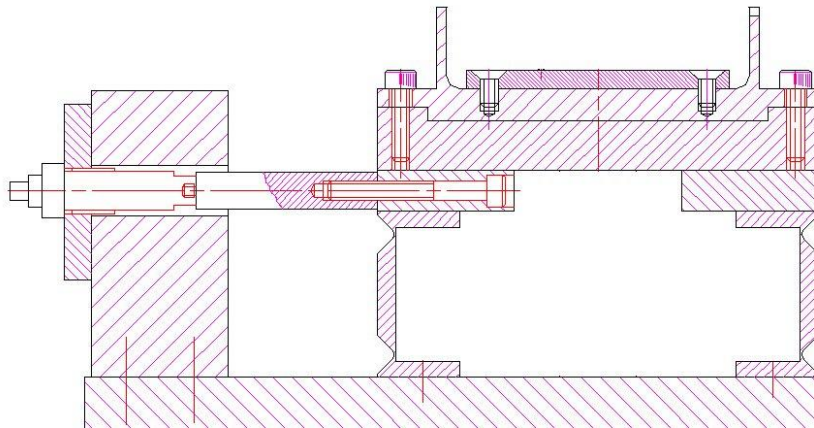

Because the flexures have low stiffness in the horizontal plane compared with the force transducer, the effective horizontal restraint on the specimen carrier is the force transducer itself. This can be modelled as a vertically restricted mass on a spring, as below:

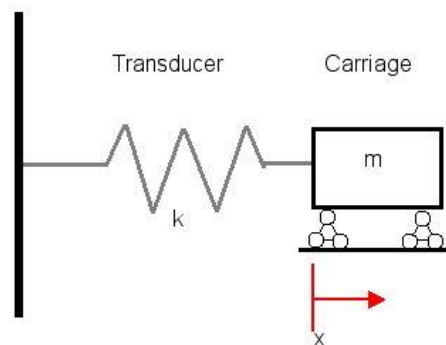

The spring is the piezo transducer. A +/-500 N piezo transducer typical has a stiffness of about 40 MN/m. The mass is the specimen carriage, with a typical weight of approximately 1 kg. For an un-damped, unforced spring the equations of motion are:

$$\begin{aligned}m\ddot{x} &= -kx \\ \ddot{x} + \frac{k}{m}x &= 0 \\ \therefore x &= A \sin\left(\sqrt{\left(\frac{k}{m}\right)}t\right) + c\end{aligned}$$

This shows that a single spring system has a natural frequency of $1/2\pi \sqrt{(k/m)}$ Hz. The TE 77 transducer/carriage assembly has a calculated natural frequency of approximately 830 Hz.

As it is good practice to use a measuring system at no more than a third of its signal bandwidth, it is appropriate that the signal from the transducer is passed through a low pass filter, in this case, with a cut-off frequency of 300 Hz, hence removing any signal

generated with a frequency above 300 Hz. This is to minimize noise in the friction signal generated from resonance of the measuring system.

Relationship between Reciprocating Frequency and Frequency Response of Measuring System

In dry or boundary lubricated reciprocating tribometers, we would normally expect the friction force to be approximately independent of sliding velocity, hence generating an approximately square wave friction signal. To demonstrate the effect on the interaction of reciprocating frequency and frequency response of measuring system, we can use a mathematically generated square wave. The Fourier equation for a square wave indicates that it can be represented by the sum of odd harmonics according to the following formula, where “f” is the fundamental frequency, which is of course the frequency of reciprocation in a reciprocating tribometer:

$$x_{\text{square}}(t) = \frac{4}{\pi} \sum_{k=1}^{\infty} \frac{\sin((2k-1)2\pi ft)}{(2k-1)}$$

$$= \frac{4}{\pi} \left(\sin(2\pi ft) + \frac{1}{3} \sin(6\pi ft) + \frac{1}{5} \sin(10\pi ft) + \dots \right).$$

Hence, if we reciprocate at 10 Hz but operate with a low pass filter of 300 Hz, the resulting signal will comprise harmonics at 10, 30, 50, 70, 90 etc, up to 290 Hz. All signal content above 290 Hz will be lost and the resulting mean signal will be attenuated.

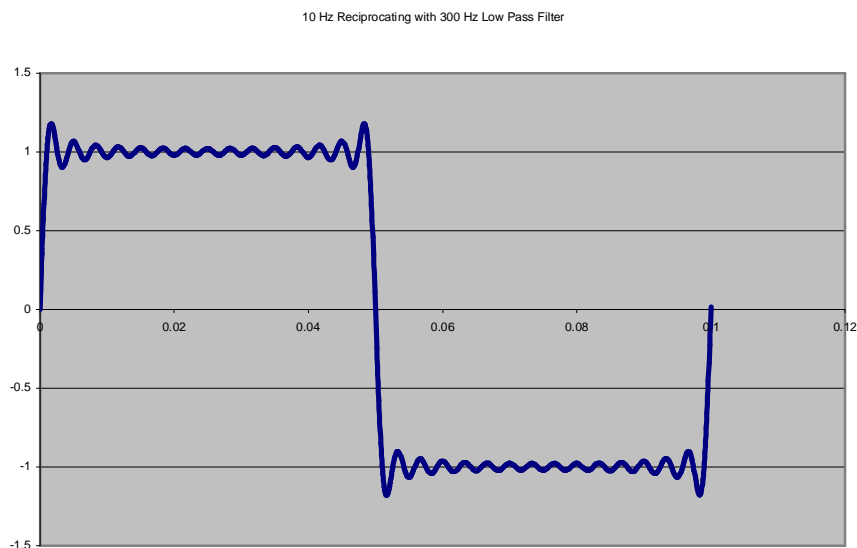

10 Hz Reciprocating Frequency Square Wave with 300 Hz Low Pass Filter

Now consider what happens when we increase the reciprocating frequency:

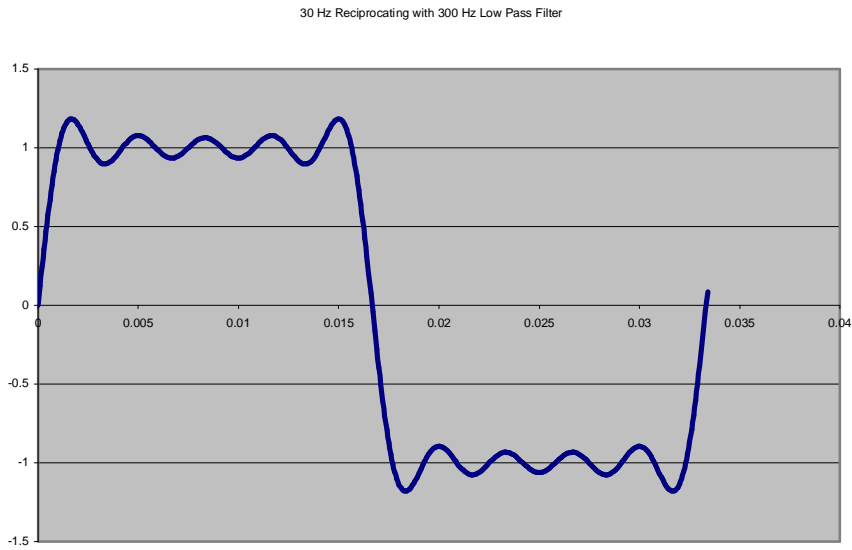

30 Hz Reciprocating Frequency Square Wave with 300 Hz Low Pass Filter
High frequency component reduced and signal attenuated

Increasing the signal bandwidth, with a corresponding increase in filter cut-off frequency allows us to achieve higher signal contact at higher reciprocating frequencies:

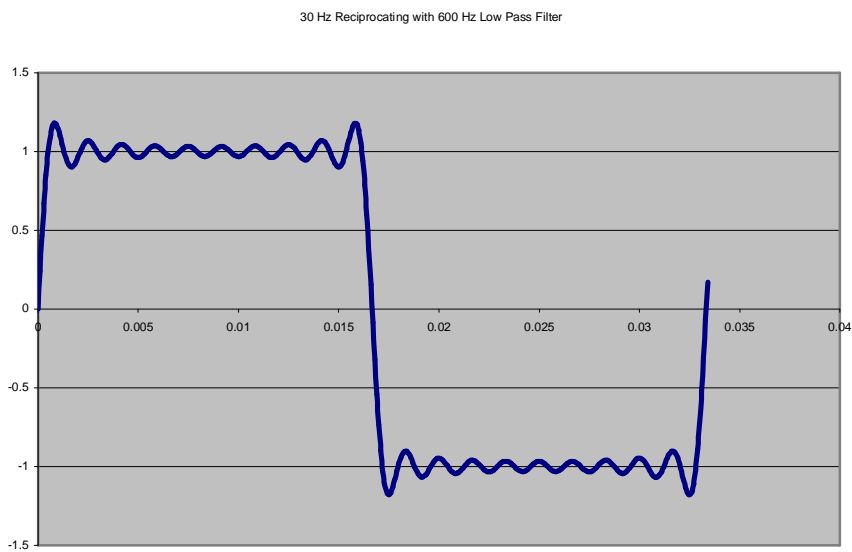

30 Hz Reciprocating Frequency with 600 Hz Low Pass Filter

Reducing the signal bandwidth with a corresponding reduction in filter cut-off frequency, without a reduction in reciprocating frequency, results in much reduced signal content.

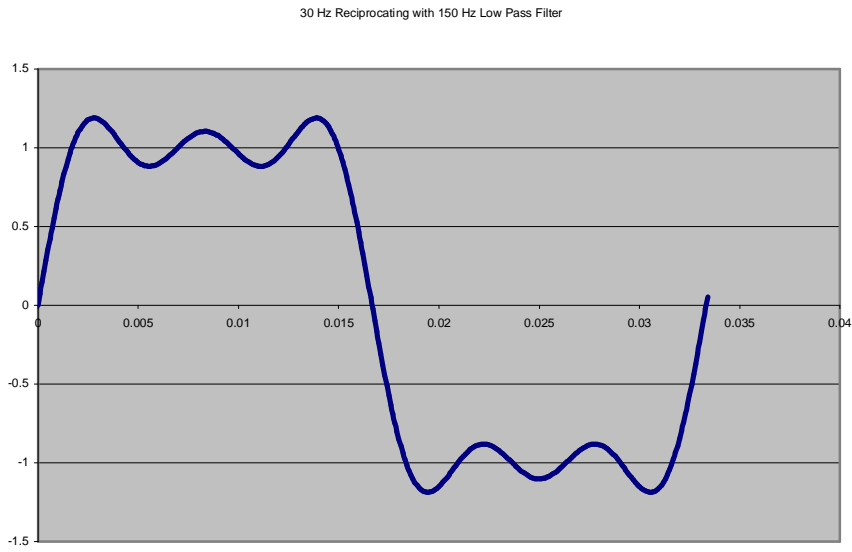

30 Hz Reciprocating Frequency Square Wave with 150 Hz Low Pass Filter

Of course, if we reduce the reciprocating frequency, we achieve improved signal content.

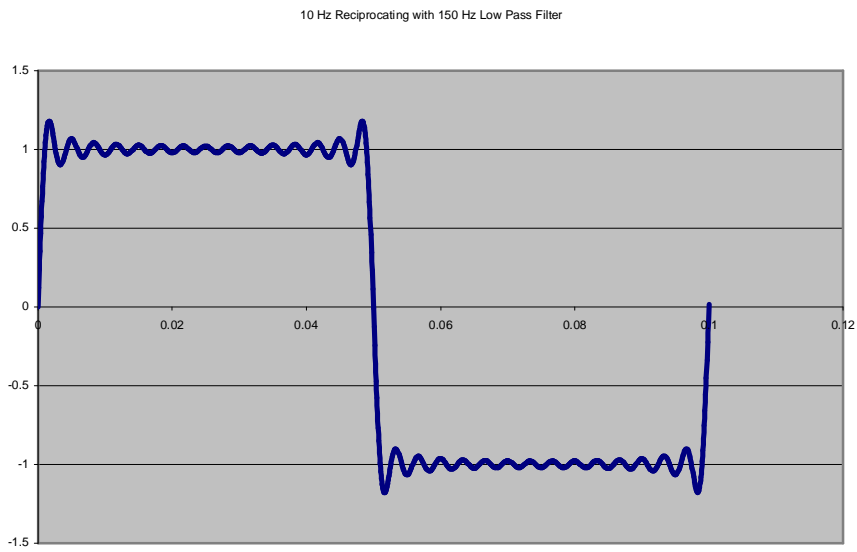

10 Hz Reciprocating Frequency with 150 Hz Low Pass Filter

2.5 Hz Reciprocating with 150 Hz Low Pass Filter

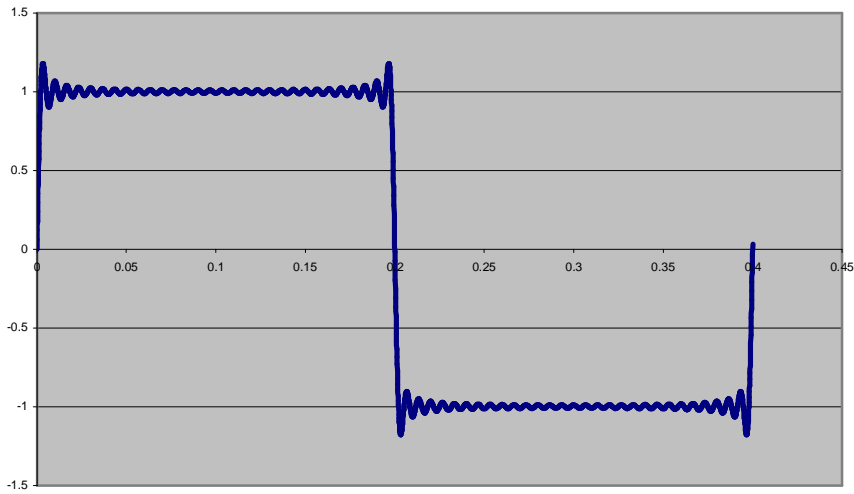

2.5 Hz Reciprocating Frequency with 150 Hz Low Pass Filter

In essence, the issue can be summarized as follows:

The lower the stiffness of the measuring system, the lower the frequency response.

The lower the frequency response, the lower the sensible reciprocating frequency.

Increasing Frequency Response

There are two ways to increase the frequency response of the measuring system, either by reducing the mass of the assembly/tooling/specimen or by increasing the stiffness of the measuring system.

Assuming that there is limited scope for reducing the mass of the test assembly, consider what might be achieved by using a stiffer transducer:

Kistler	Range +/-	Threshold	Rigidity	Linearity	Linearity	Hysteresis	Hysteresis	Natural Frequency***	Low Pass Filter
	N	mN	N/micron	+/--%FSO	+/-N	%FSO	N	Hz	Hz
9203	500	1	40	1	5	0	0	1006	335
9301B	2500	20	300	0.5	12.5	0.5	12.5	2756	918
9311B	5000	20	600	0.5	25	0.5	25	3898	1299

It will be noted that although there are significant gains to be made in terms of increased natural frequency from using a stiffer and hence higher load range transducer, there are corresponding losses in terms of sensitivity, linearity and hysteresis.

In essence, the lower the force we may wish to measure, the less stiff the measuring system and the lower the frequency response, hence the lower the frequency of variation in force that can be detected.

Assuming that we wish to keep signal content including frequencies up to the thirtieth odd harmonic, we end up with comparable content signals as follows:

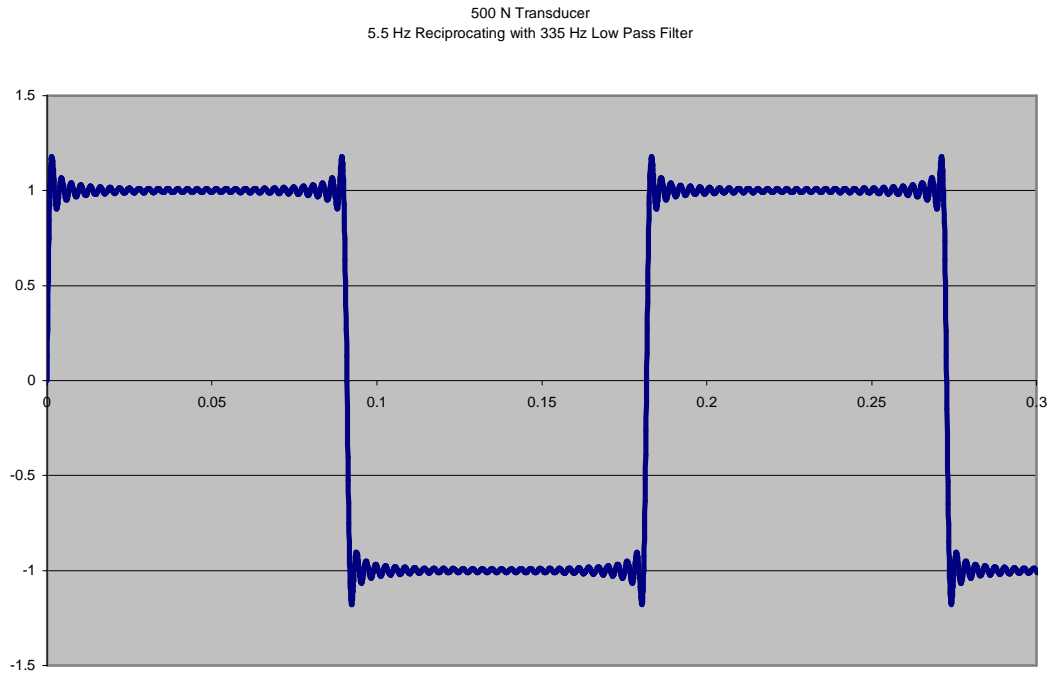

2500 N Transducer
15 Hz Reciprocating with 918 Hz Low Pass Filter

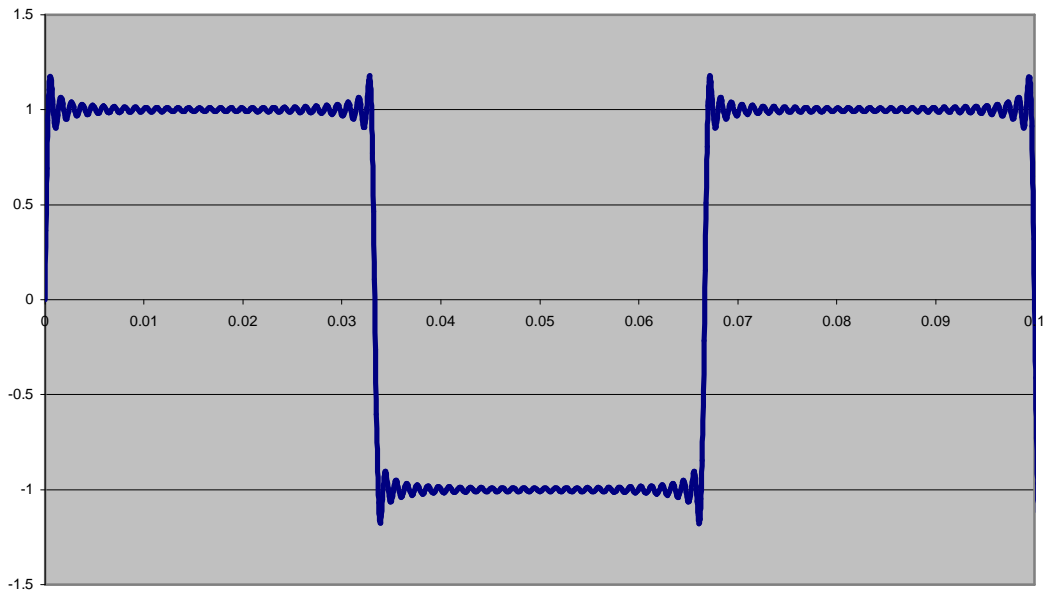

5000 N Transducer
21 Hz Reciprocating with 1299 Hz Low Pass Filter

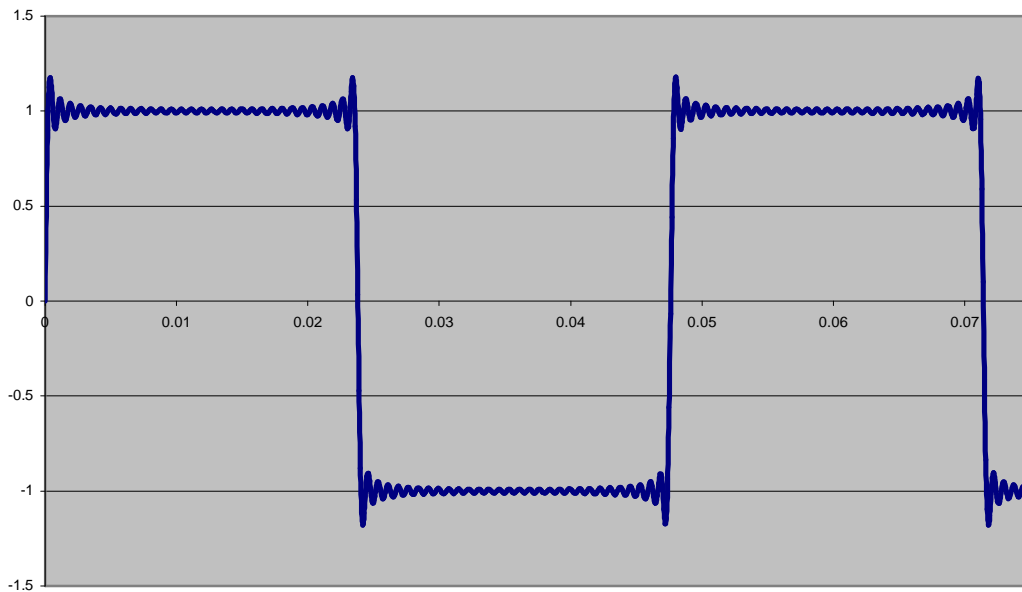

Hence, replacing our 500 N piezo transducer with a 5000 N transducer allows us, in this example, to increase the reciprocating frequency from 5.5 Hz to 21 Hz, while retaining the same signal information.

Effect of Filtering on "Mean" Value of Friction Signal

We should of course note that, even if the friction remains substantially constant, with true force independent of reciprocating frequency, increasing the reciprocating frequency will cause the apparent “mean” force value to fall. This is because as the reciprocating frequency increases relative to the frequency response of the measuring

system, the information content of the signal decreases. This can be illustrated using the idealized square wave and the mathematical equivalent of an r.m.s. to d.c. converter. In this example, the sampling rate will be set high enough to prevent aliasing as a source of potential error.

5 Hz Reciprocating with 300 Hz Low Pass Filter - Rectified

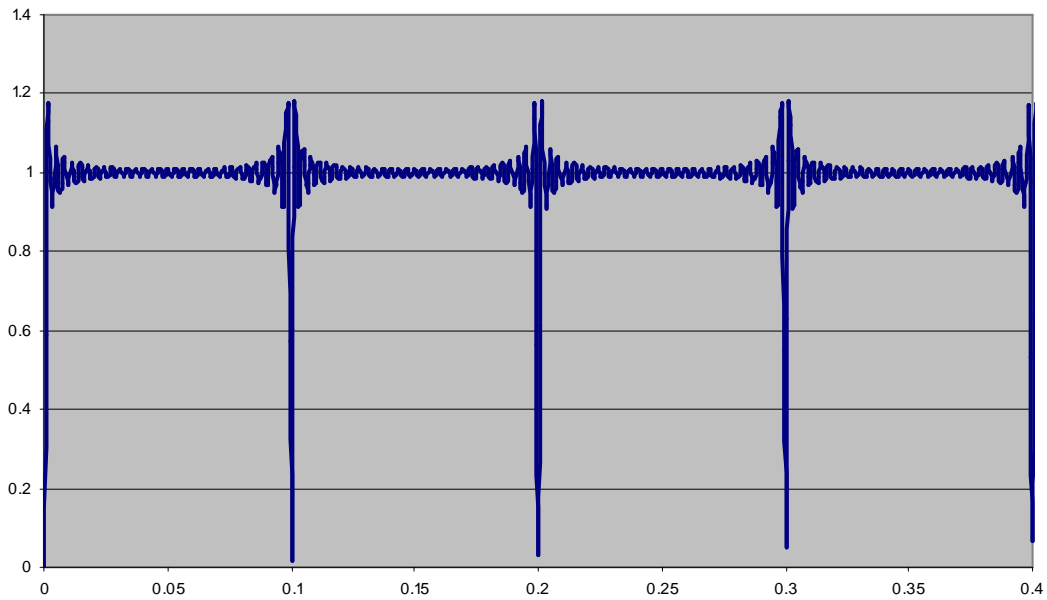

10 Hz Reciprocating with 300 Hz Low Pass Filter - Rectified

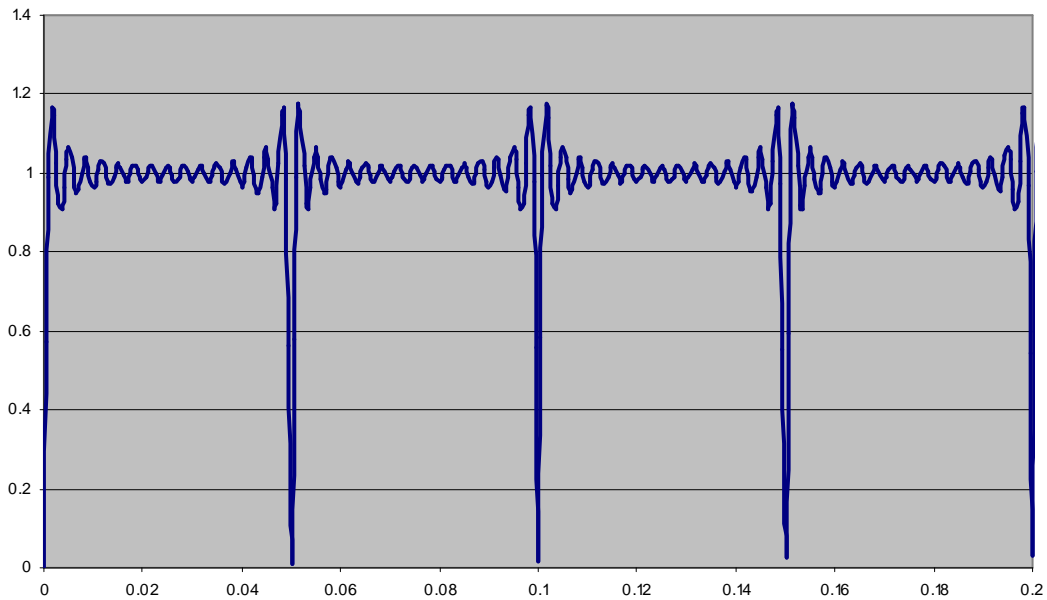

Attenuation with 300 Hz Low Pass Filter

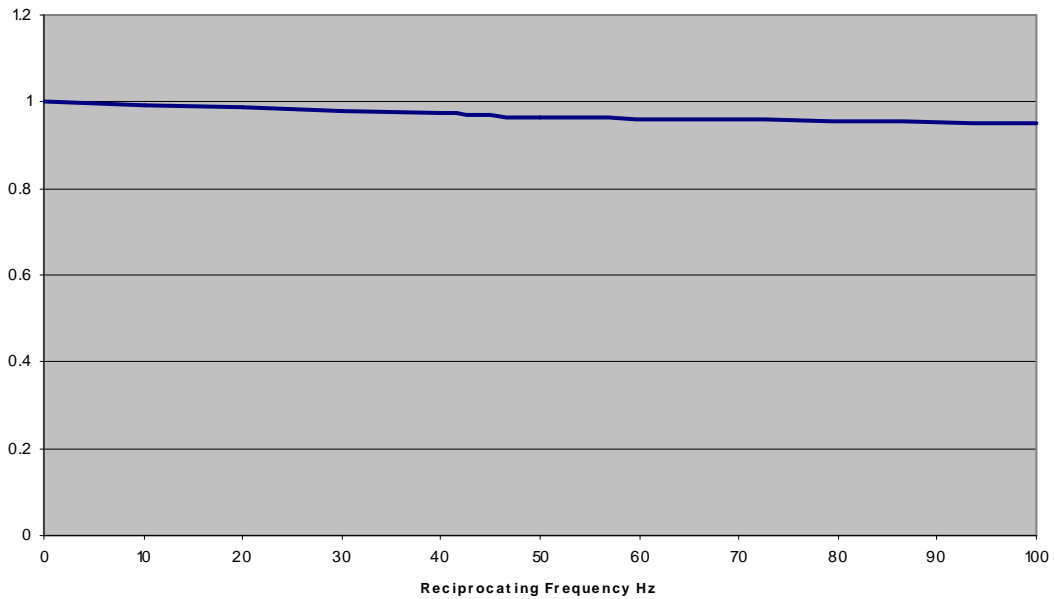

Frequency:	Value:
Hz	
0	1.000
10	0.993
20	0.987
30	0.979
40	0.974
50	0.966
100	0.949

Hence, we can see that, assuming that we have a perfect square wave input signal of amplitude 1, at 100 Hz reciprocating frequency, with a low pass filter set at 300 Hz, we will have an apparent reduction in mean value of approximately 5%. This is of course an artefact, not a real reduction in the input signal.

There is of course a substantial caveat to be applied to all the examples and analysis produced above and that is the assumption that we have:

A perfect square wave signal with no superimposed spikes, variations with velocity or an-isotropic behaviour.

A perfect Low Pass Filter with a characteristic as follows:

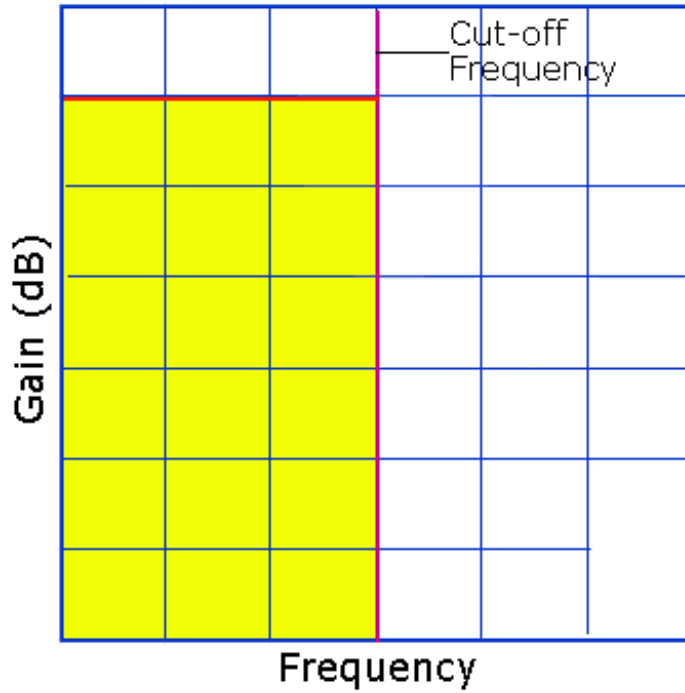

When real filters, of which there are many types, look like this:

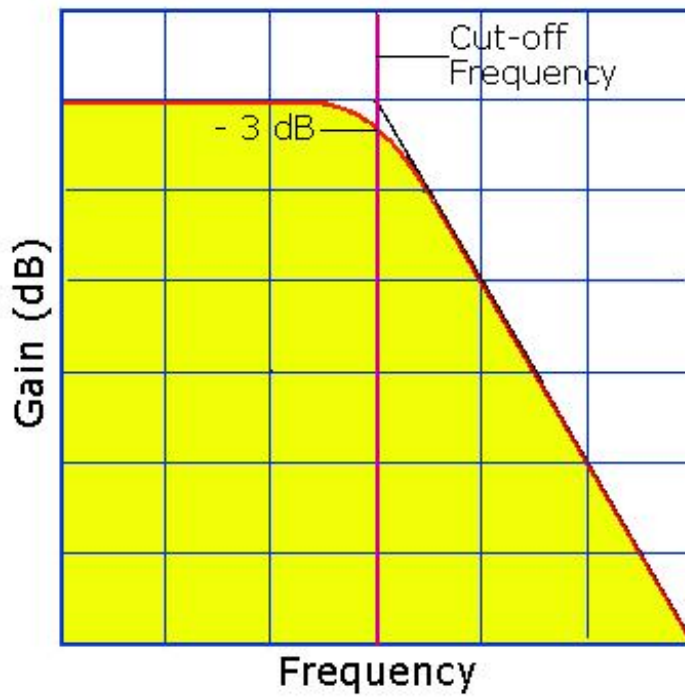

which results in increased attenuation.

It is obviously hazardous, in the absence of detailed analysis of the frequency response of the measuring system and signal processing, to compare mean friction levels at different reciprocating frequencies. It should be noted that this has nothing to do with stroke length, simply reciprocating frequency. As we increase the reciprocating frequency the greater the loss of signal content for a fixed signal bandwidth measuring system, giving the (false) appearance of a reduction in friction with increasing frequency.

Measuring System Resonance

The preceding analysis ignored the effect of the transition from static friction to dynamic friction on the measuring system. This transition occurs at the beginning of each stroke and the resulting resonance is apparent in all unfiltered reciprocating tribometer friction force measurements, assuming that a system with sufficient signal bandwidth is available.

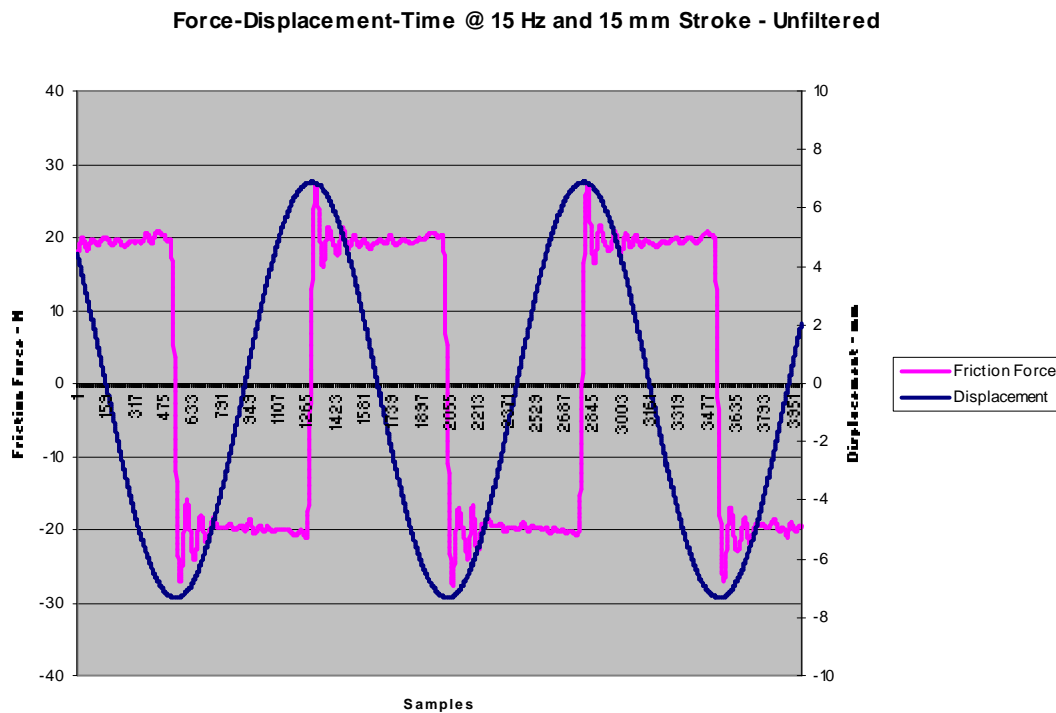

The above graph shows an unfiltered friction force signal from a standard TE 77 High Frequency Friction Machine, running at 15 Hz and 15 mm stroke. Whereas the initial peak signal at the start of the stroke may indicate the limiting static friction the subsequent oscillating spikes are not friction effects! The signal perturbation cannot be anything other than a resonant harmonic force superimposed on a quasi steady state signal, giving rise to under-damped harmonic oscillation.

This is a common feature of all reciprocating tribometer nominal friction force measurements: reversal of the friction force at the beginning of the stroke effectively “plucks” the force measuring system rather like plucking a string. The magnitude of the resulting oscillations is of course a function of the magnitude of the “plucking” force.

The rate of decay of the resulting vibration signal is a function of the inertia of the sample assembly (sample, bath, tooling etc) and the stiffness of the transducer, both of which tend to be constant, and the variable damping coefficient of the system, which is a function of the friction in the contact. With knowledge of the mass (inertia) and stiffness of the system, the resonance can be modelled exactly.

Time for the signal to decay is fixed for a given damping coefficient. It follows that the higher the frequency of reciprocation, the greater the percentage of the force signal that includes superimposed resonance.

Confirmation of this resonance effect can be demonstrated by a simple experiment. A mass is attached to the transducer assembly by means of a string and pulley arrangement. Cutting the string “plucks” the assembly. The experiment can be performed with or without the specimens loaded in contact to model the effect of friction damping. It should be noted that damping always reduces the natural frequency of any system. Results for the TE 77 High Frequency Friction Machine are as follows:

20 N Pulse - Undamped

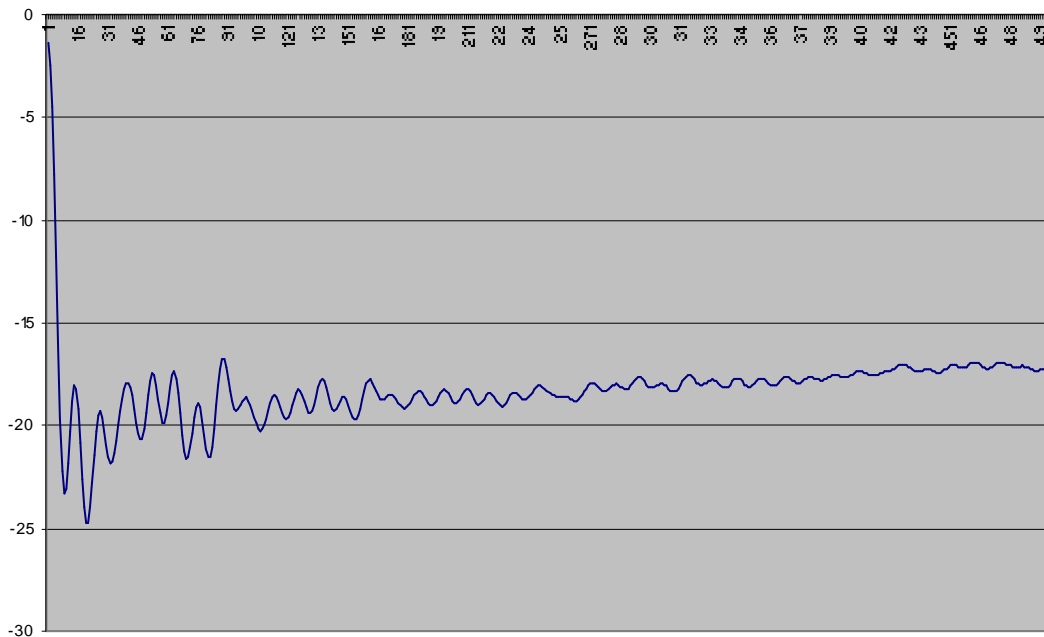

Measurement of the period of oscillation from both the friction signal and the “plucking” experiments indicates a resonant frequency, with and without friction damping, in the range 822 to 833 Hz, in other words, sufficiently close to the calculated value to be beyond doubt.

Similar friction data has been provided by users of the Optimol SRV and analysis of one trace, chosen at random, follows:

Instantaneous Friction

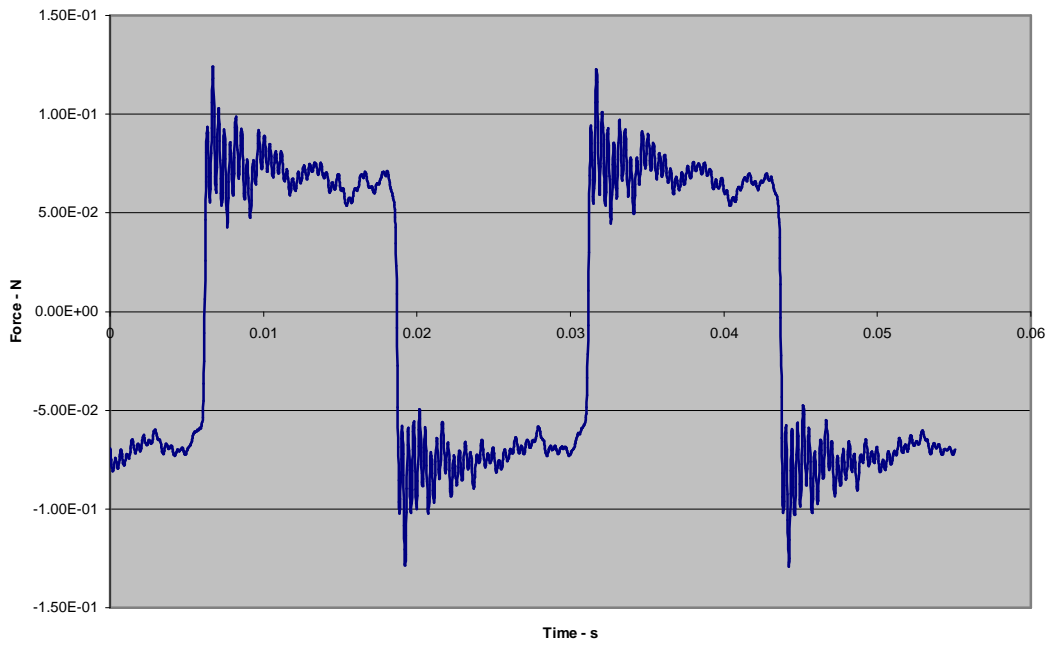

High Speed Force Signal Plotted in Time Domain

Resonance Signal

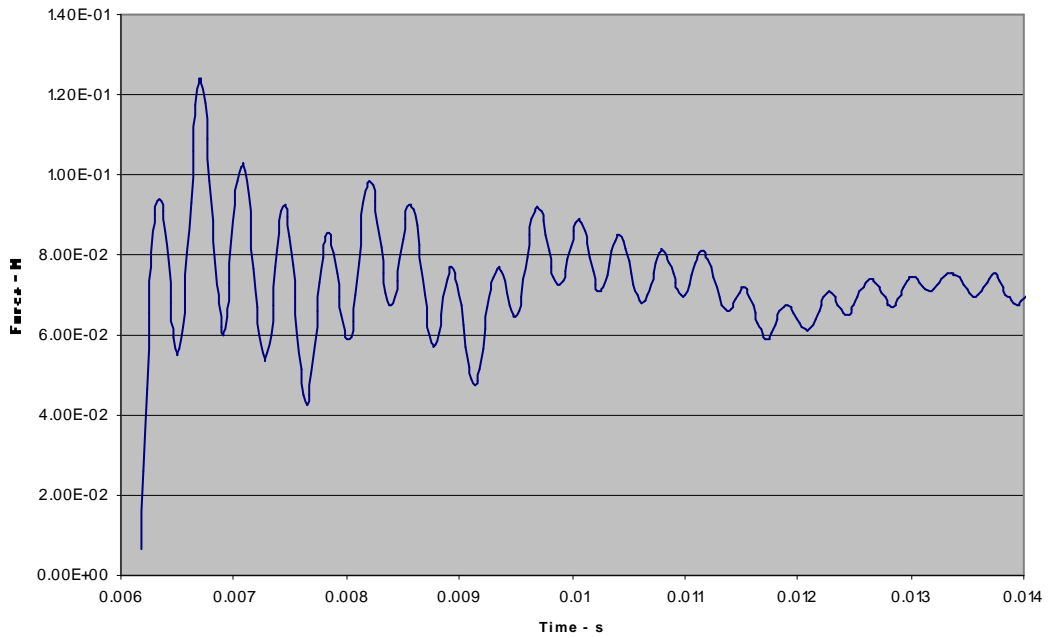

Force Signal Detail – Stroke Beginning

Data Points for Peaks and Troughs

		Time Resolution	0.000024S		
Peaks	Time	Period	+/- Resolution	Adjusted Period	Force
	s	s			N
1	0.006348				9.37E-02
2	0.006519	0.000171	Zero	0.000171	5.52E-02
3	0.006714	0.000195	Minus	0.000171	0.1239011
4	0.006909	0.000195	Minus	0.000171	6.02E-02
5	0.007080	0.000171	Zero	0.000171	0.1029952
6	0.007275	0.000195	Minus	0.000171	5.37E-02
7	0.007446	0.000171	Zero	0.000171	9.24E-02
8	0.007642	0.000195	Minus	0.000171	4.27E-02
9	0.007837	0.000195	Minus	0.000171	8.57E-02
10	0.008032	0.000195	Minus	0.000171	5.94E-02
11	0.008203	0.000171	Zero	0.000171	9.87E-02
	Mean	0.000186			

The period of oscillation at the start of the stroke is constant to within less than +/- one bit resolution. Once again, the signal cannot be anything other than a resonant harmonic force superimposed on a quasi steady state signal, giving rise to under-damped harmonic oscillation.

In the case of this example signal, approximately the first half of the force signal is made up of the sum of friction force and resonance, with the second half of the signal mostly friction, following the decay of the resonance. It follows that running the same experiment at half the reciprocating frequency, hence twice the period, the resonance effect would be limited to the first quarter of the wave form, in other words, the lower the frequency of oscillation, the better the noise (harmonic vibration) to signal (friction force) ratio.

It should be noted:

that this resonance effect is essentially independent of stroke length.

that the amplitude of resonant oscillations will increase with increasing static friction, but no doubt with a corresponding increase in damping coefficient.

that the resonance, if processed by a true r.m.s. to d.c. filter, adds to the mean force signal and thus distorts the mean "friction" force.

Effect of Static Friction Force and Friction Damping on Magnitude of Resonance

Further work is required before a definitive answer can be given with regard to the influence of static and dynamic friction on the magnitude of resonance and damping coefficient, but differences are apparent from the limited number of experiments performed to date

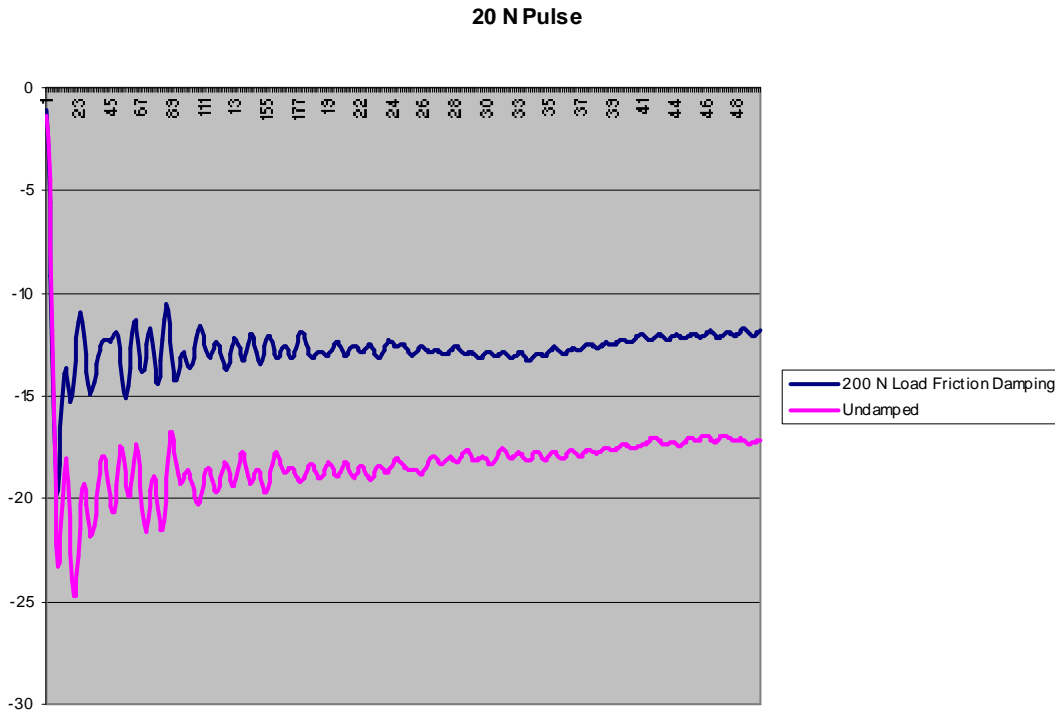

The above graph shows the resulting of a TE 77 “plucking” experiment with a 20 N pulse, with and without a frictional contact. In the case of friction damping, a lubricated ball on plate sample is used with a static load of 200 N applied. The only conclusion that can be drawn at this stage is that the resonant behaviour of the measuring system, as would be expected, alters as the contact load, hence “plucking” force and friction damping coefficient change.

As with the uncertain effects of running experiments at different frequencies and comparing friction measurements, we should be more cautious when it comes to reporting friction data at different loads. This may go some way towards explaining the slightly anomalous behaviour reported in experiments involving ramped loads.

Choice of Filter

It would perhaps be an omission to conclude without stating a preference for a particular type of filter for reciprocating tribometer applications. The best filter for time domain applications is a Bessel filter, a type of filter frequently used for cleaning up digital signals, which are perhaps a good analogue for a dry or boundary lubricated friction signal. It provides minimum distortion of rapid slope changes, a uniform group delay and the lowest wideband noise. A Bessel filter is less well suited to frequency domain applications as it has a drooping amplitude response and a gentler cut-off frequency than other filter types. An 8-pole Bessel filter will prove more than adequate for most applications.

Conclusions

The analysis presented here is by no means exhaustive and indeed ignores another potential source of resonance, the dynamic resonance of components on the opposite side of the frictional contact from the force measuring system, in other words, the reciprocating drive system. Whereas this can perhaps be ignored with a stiff and low inertia mechanical drive arrangement, systems incorporating high inertia and varying stiffness electro-magnetic oscillator drives may well behave somewhat differently. This is perhaps an area for others to investigate further.

To summarise:

The lower the stiffness of the measuring system, the lower the frequency response.

The lower the frequency response, the lower the permissible reciprocating frequency.

Increasing reciprocating frequency results in greater loss of signal content for a fixed signal bandwidth measuring system.

Signal resonance at the beginning of the stroke should not be confused with frictional effects.

The time for the resonance signal to decay is fixed for a given damping coefficient, hence the higher the frequency of reciprocation, the greater the percentage of the force signal that includes superimposed resonance.

The resonance, if processed by a true r.m.s. to d.c. filter, will add to the mean force signal and thus distorts the mean "friction" force.

These effects are independent of stroke length.

A preference for running reciprocating tests, where possible, at longer strokes and lower frequencies, as opposed to shorter strokes and higher frequencies, should be obvious.